

| LEFT SIDE COMPARTMENTATION |         |                    |                                   |            |
|----------------------------|---------|--------------------|-----------------------------------|------------|
| COMPT                      | DOORS   | OPENING DIMENSIONS | INSIDE DIMENSIONS                 | VOLUME     |
| L1                         | ROLL-UP | 37" w X 56 7/8" h  | 43" w X 66" h X 27 1/4" d         | 40 CU. FT. |
| L2                         | ROLL-UP | 57" w X 27 5/8" h  | 61 1/2" w X 36 1/2" h X 27 1/4" d | 30 CU. FT. |
| L3                         | ROLL-UP | 50" w X 56 7/8" h  | 56" w X 66" h X 27 1/4" d         | 52 CU. FT. |

| RIGHT SIDE COMPARTMENTATION |         |                    |                                   |                               |
|-----------------------------|---------|--------------------|-----------------------------------|-------------------------------|
| COMPT                       | DOORS   | OPENING DIMENSIONS | INSIDE DIMENSIONS                 | VOLUME                        |
| R1                          | ROLL-UP | 37" w X 56 7/8" h  | 43" w X 66" h X 27 1/4" d         | 26 CU. FT. 10 1/2" DEEP UPPER |
| R2                          | ROLL-UP | 57" w X 27 5/8" h  | 61 1/2" w X 36 1/2" h X 10 1/2" d | 13 CU. FT.                    |
| R3                          | ROLL-UP | 50" w X 56 7/8" h  | 56" w X 66" h X 27 1/4" d         | 34 CU. FT. 10 1/2" DEEP UPPER |

| REAR STEP COMPARTMENTS |         |                    |                           |            |
|------------------------|---------|--------------------|---------------------------|------------|
| COMPT                  | DOORS   | OPENING DIMENSIONS | INSIDE DIMENSIONS         | VOLUME     |
| A1                     | ROLL-UP | 37 1/2" w X 31" h  | 40" h X 40" w X 29 1/2" d | 27 CU. FT. |

TOTAL STORAGE: 222 cu. ft.

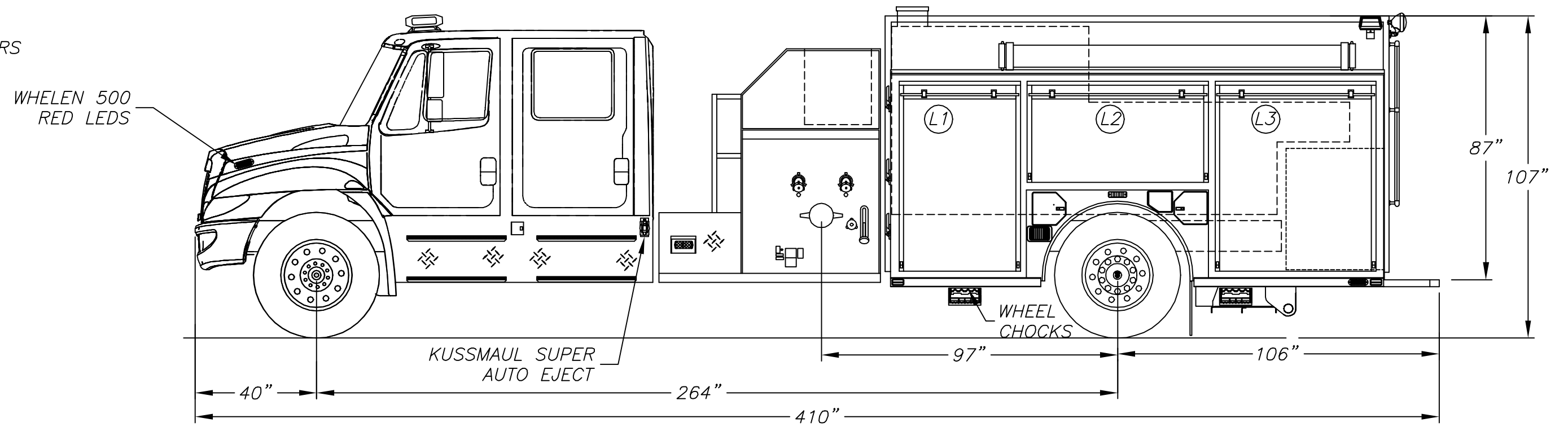
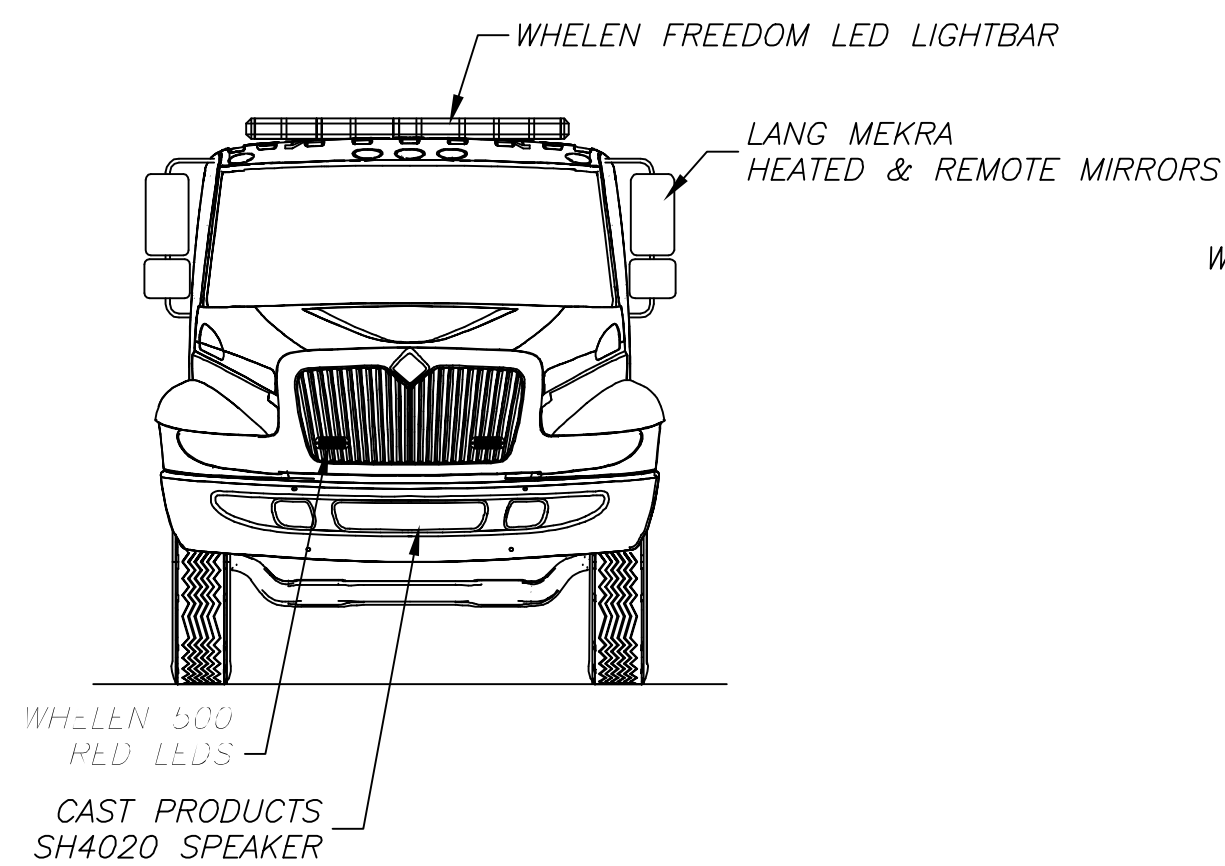
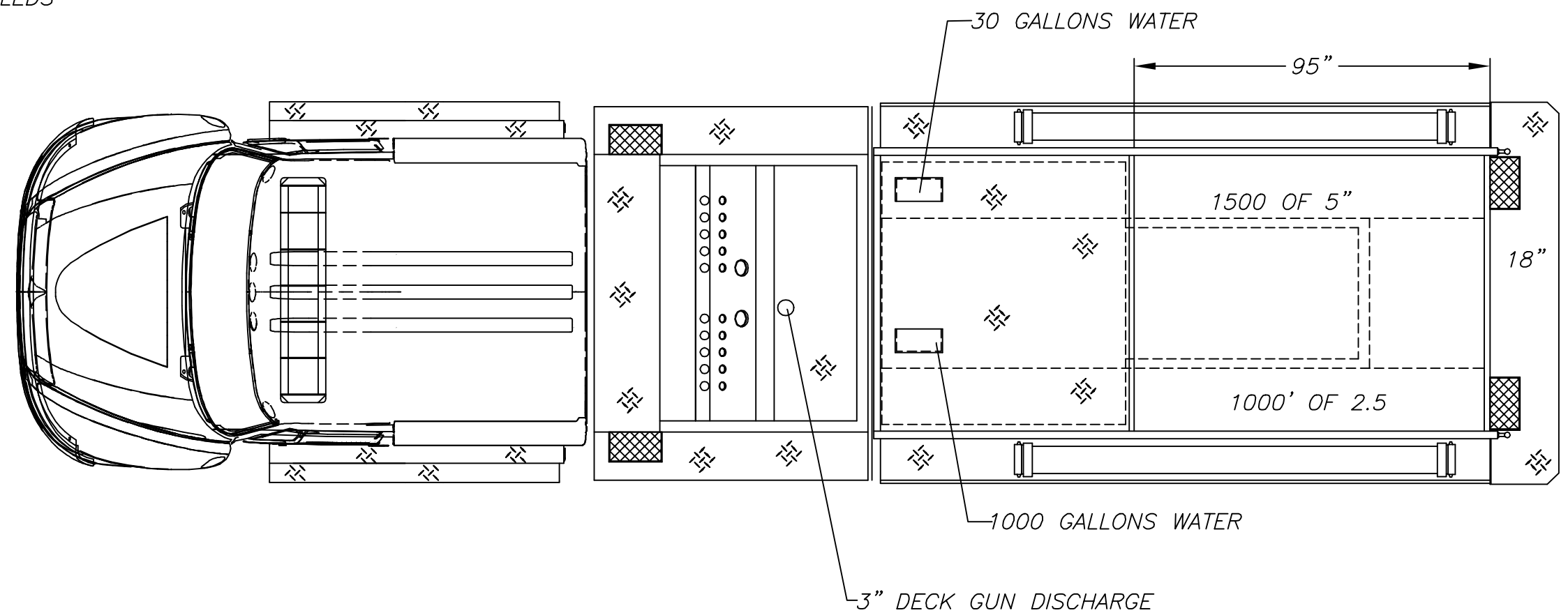

NOTE:  
1) DECKGUN FLANGE FLUSH WITH SIDE METAL.

THE INFORMATION PRESENTED ON THIS DOCUMENT IS TO BE USED FOR ILLUSTRATIVE PURPOSES ONLY AND IT MAY NOT REFLECT, AESTHETICALLY OR OTHERWISE, PAST OR PRESENT MANUFACTURED PRODUCTS. SUTPHEN CORPORATION RESERVES THE RIGHT TO MAKE CHANGES IN THE DESIGN OF OUR PRODUCTS AT ANY TIME, WITHOUT NOTIFICATION.

The undersigned approves this data for construction in accordance with any changes as indicated on these drawings.  
APPROVED BY: \_\_\_\_\_ DATE: \_\_\_\_\_  
(Authorized Fire Dept. Representative)  
SALES REPRESENTATIVE: \_\_\_\_\_ DATE: \_\_\_\_\_

| REV. | DESCRIPTION                  | BY  | DATE   |
|------|------------------------------|-----|--------|
| A    | REVISED THE CHEVRON STRIPING | RDG | 7/9/09 |

THIS PRINT IS PROVIDED ON A RESTRICTED BASIS AND IS NOT TO BE USED IN ANY WAY DETRIMENTAL TO THE INTEREST OF SUTPHEN CORPORATION.

**SUTPHEN CORPORATION**  
FIRE APPARATUS SINCE 1890  
7000 COLUMBUS-MARYSVILLE ROAD  
AMLIN, OHIO 43002

DR. R. GROVE  
DATE 5/8/09  
SCALE NONE

STOCK 274

NO. REQ'D.  
DWG. NO.  
HS-4731