

PRELIMINARY DRAWING - FOR LAYOUT PURPOSES ONLY

REVISIONS			
REV	DESCRIPTION	DATE	BY

NOTE 1: Do not scale drawing. This drawing is for general truck configuration only. All items and dimensions shown are approximate and may vary with final production. The drawing may not provide illustration for all items in the specification. In all situations where the drawing may contradict the specifications, the specifications shall prevail. This drawing and all data herein are provided as confidential materials and shall not be reproduced without written consent of the manufacturer.

NOTE 2: Chassis frame height will change due to axle characteristics, loading and tire dimensions which will affect the overall height dimension shown. Any overall height restrictions should take this into consideration and allow approximately 2-3 inches of tolerance.

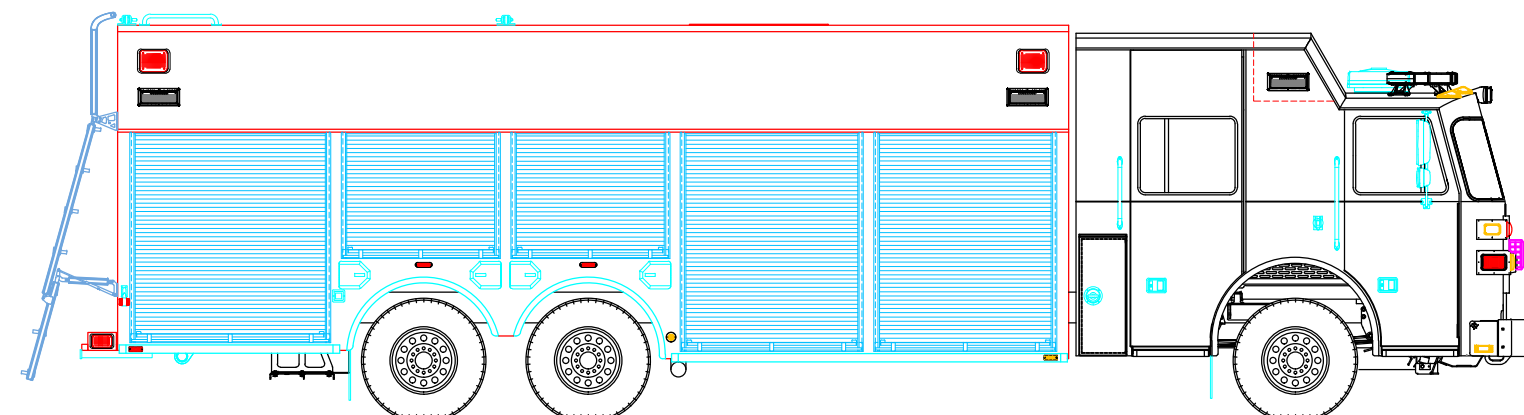
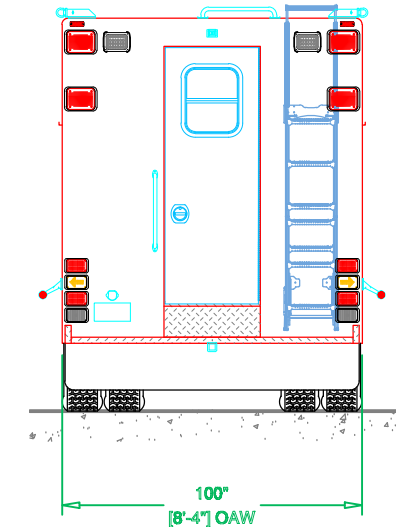
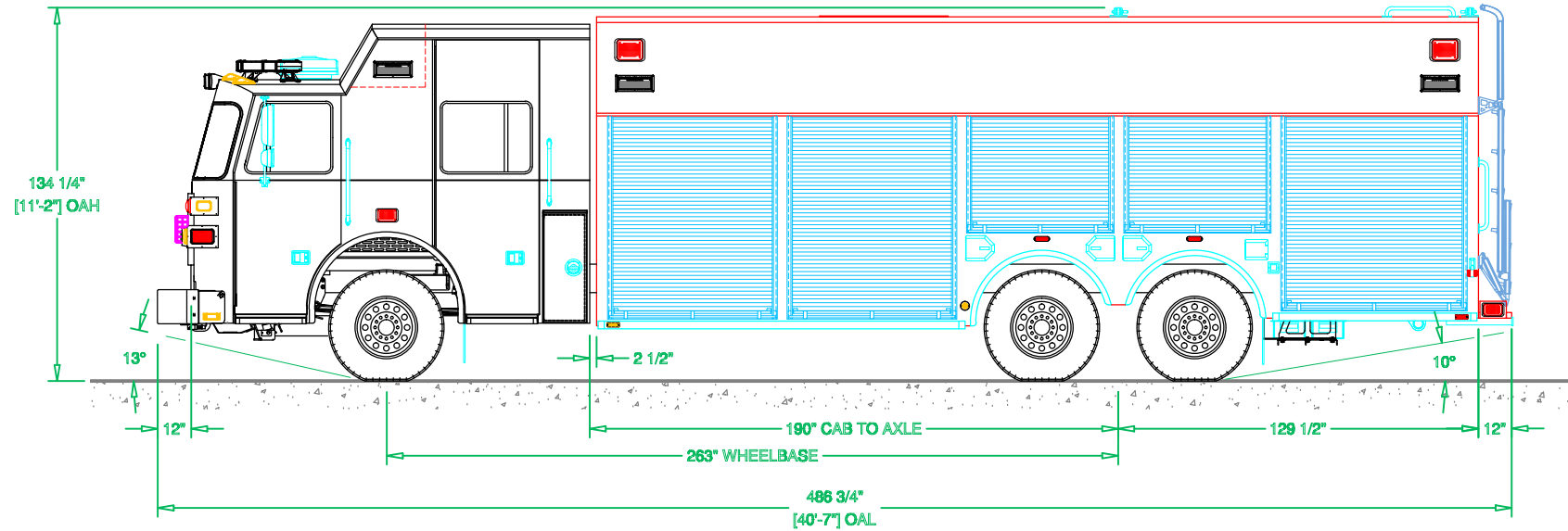
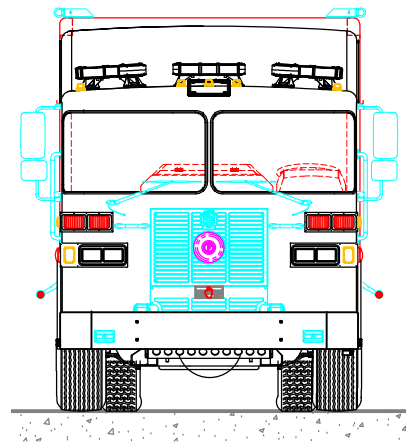
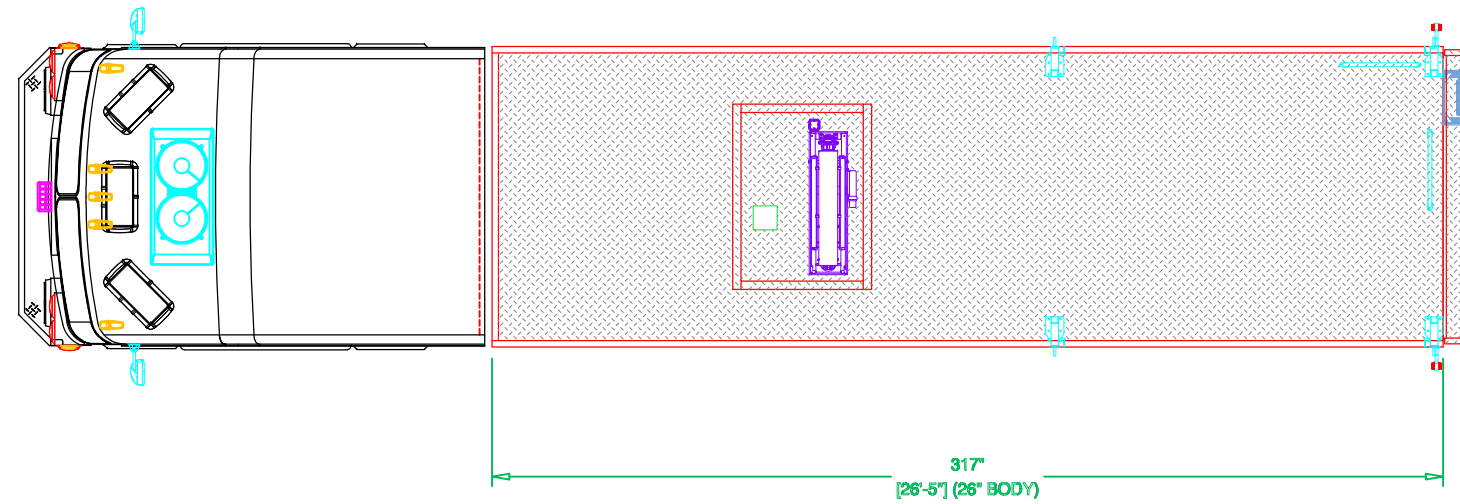

THIS PRINT IS PROVIDED ON A RESTRICTED BASIS AND IS NOT TO BE USED IN ANY WAY DETRIMENTAL TO THE INTEREST OF SUTPHEN CORPORATION.

SUTPHEN CORPORATION
 FIRE APPARATUS SINCE 1890
 7000 COLUMBUS-MARYSVILLE ROAD
 AMLIN, OHIO 43002

**ELKHART
 FIRE DEPARTMENT**

BODY SIZE: 26' BODY	UNIT TYPE: HEAVY RESCUE WALK - IN
BODY MATERIAL: 3/16" ALUMINUM	TRUCK NO: SV1 #xxx
CHASSIS TYPE: SUTPHEN MONARCH 73"	WHEELBASE: SEE DWG
20" RR	CAB TO AXLE: SEE DWG
FOUR DOOR	OVERALL LENGTH (OAL): SEE DWG
	OVERALL WIDTH (OAW): SEE DWG
	OVERALL HEIGHT (OAH): SEE DWG

DRAWN BY: **BCG** DATE: **April 8, 2022** SCALE: **3/16" = 1'-0"**
 DRAWING NO: **Elkhart IN wt 28 PreCon2** SHEET **1** OF **3**

PRELIMINARY DRAWING - FOR LAYOUT PURPOSES ONLY

REVISIONS			
REV	DESCRIPTION	DATE	BY

NOTE 1: Do not scale drawing. This drawing is for general truck configuration only. All items and dimensions shown are approximate and may vary with final production. The drawing may not provide illustration for all items in the specification. In all situations where the drawing may contradict the specifications, the specifications shall prevail. This drawing and all data herein are provided as confidential materials and shall not be reproduced without written consent of the manufacturer.

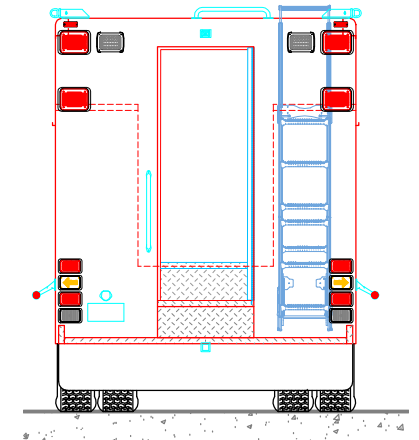
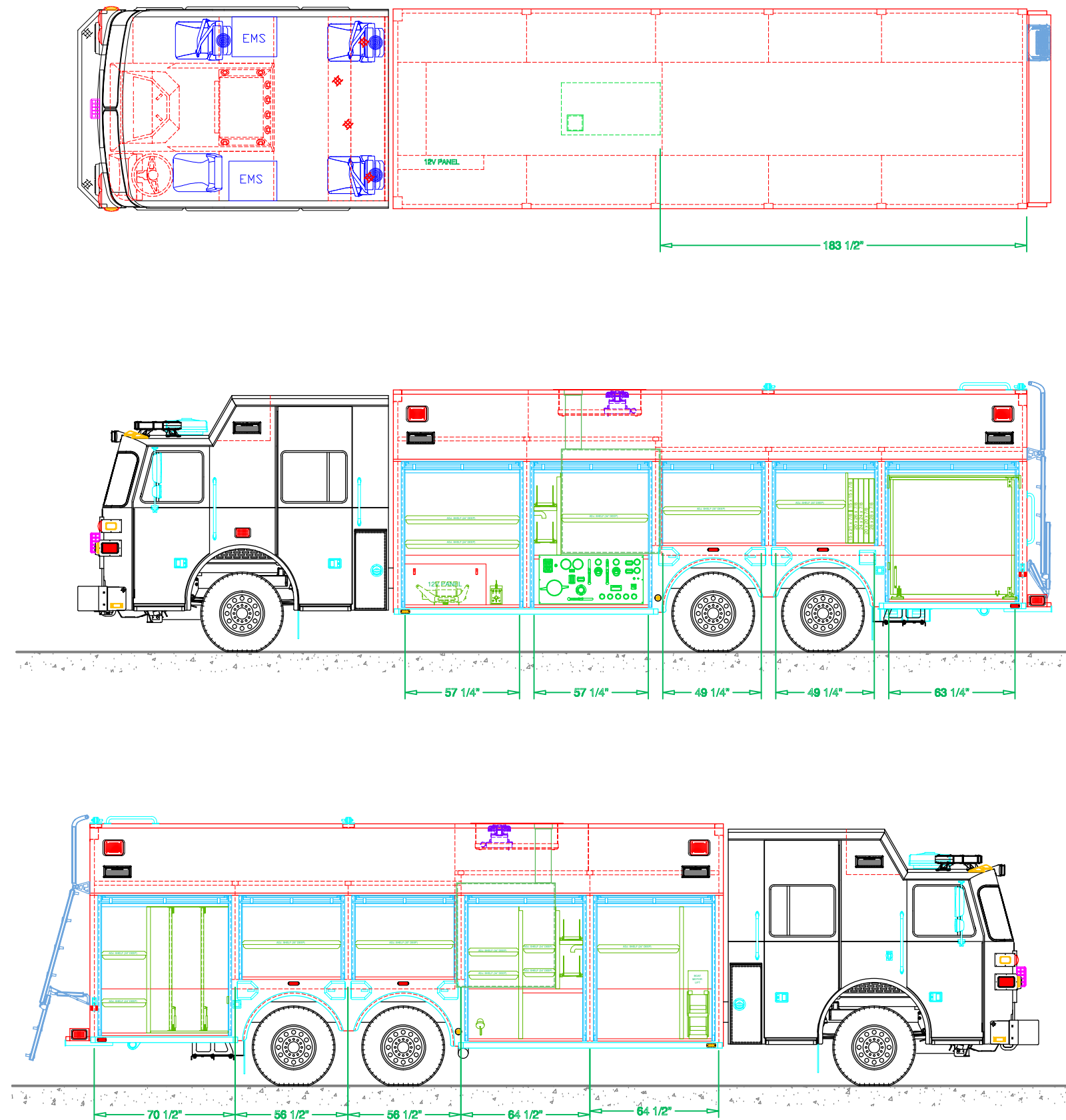

THIS PRINT IS PROVIDED ON A RESTRICTED BASIS AND IS NOT TO BE USED IN ANY WAY DETRIMENTAL TO THE INTEREST OF SUTPHEN CORPORATION.

SUTPHEN CORPORATION
 FIRE APPARATUS SINCE 1890
 7000 COLUMBUS-MARYSVILLE ROAD
 AMLIN, OHIO 43002

**ELKHART
 FIRE DEPARTMENT**

BODY SIZE: 28' BODY	UNIT TYPE: HEAVY RESCUE WALK - IN
BODY MATERIAL: 3/16" ALUMINUM	TRUCK NO: SVI #000
CHASSIS TYPE: SUTPHEN MONARCH 73" 20" RR	WHEELBASE: SEE DWG CAB TO AXLE: SEE DWG
	OVERALL LENGTH (OAL): SEE DWG OVERALL WIDTH (OAW): SEE DWG OVERALL HEIGHT (OAH): SEE DWG
DRAWN BY: BCG	DATE: April 8, 2022
DRAWING NO: Elkhart IN wt 28 PreCon2	SCALE: 3/16" = 1'-0"

SHEET **2** OF **3**

PRELIMINARY DRAWING - FOR LAYOUT PURPOSES ONLY

REVISIONS			
REV	DESCRIPTION	DATE	BY

NOTE 1: Do not scale drawing. This drawing is for general truck configuration only. All items and dimensions shown are approximate and may vary with final production. The drawing may not provide illustration for all items in the specification. In all situations where the drawing may contradict the specifications, the specifications shall prevail. This drawing and all data herein are provided as confidential materials and shall not be reproduced without written consent of the manufacturer.

PLAN VIEW
CROSS-SECTION

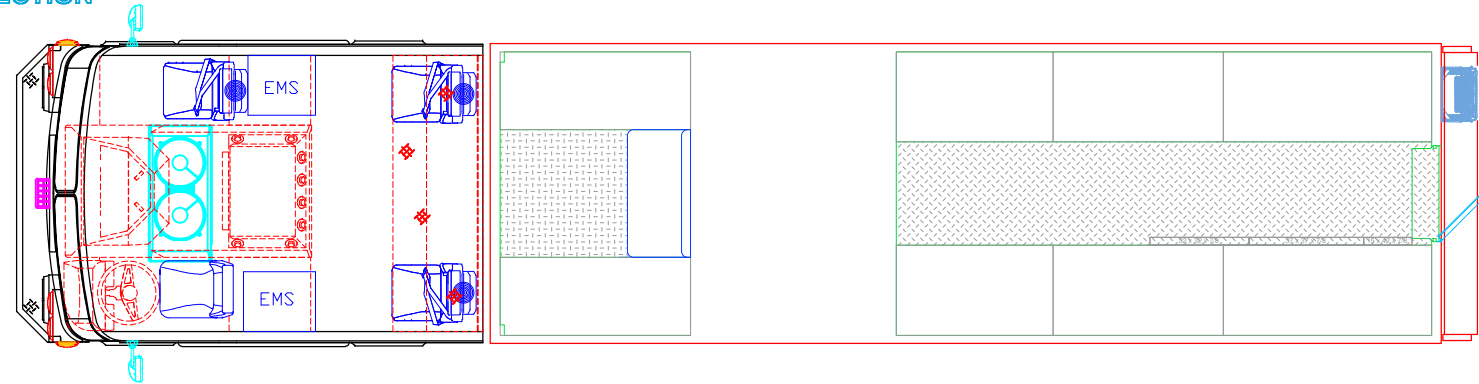

FRONT VIEW OF BODY
CROSS-SECTION

CAB TO BODY WALK-THRU
DOOR W/O SLIDING POCKET

REAR VIEW OF BODY
CROSS-SECTION

CURBSIDE INTERIOR
CROSS-SECTION

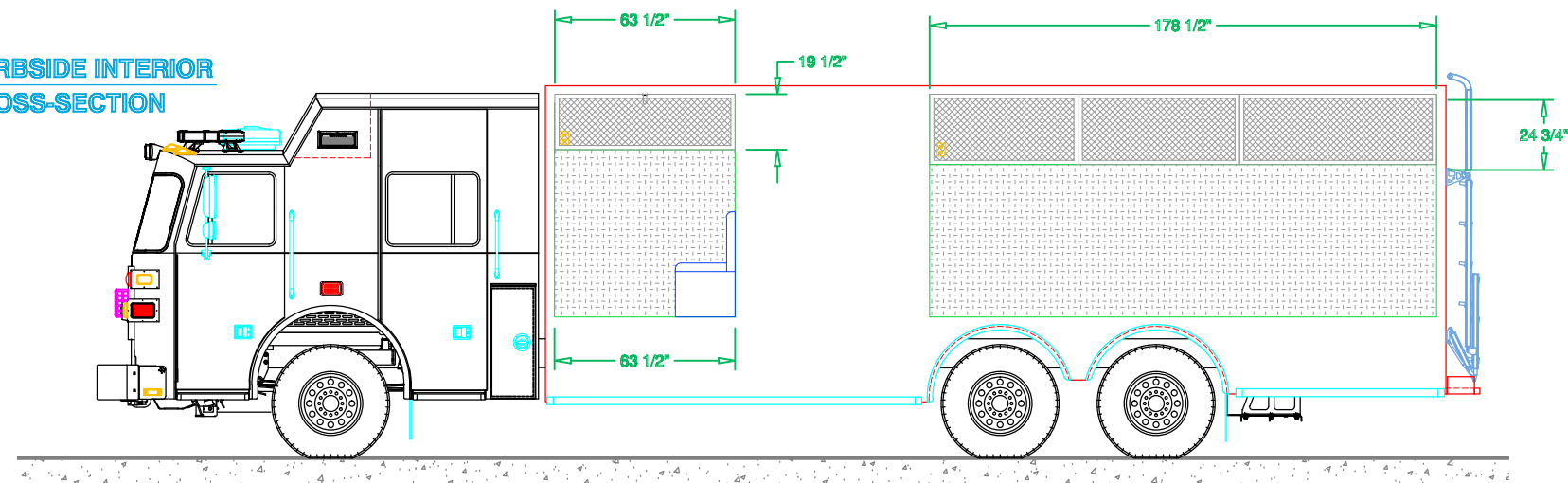

STREETSIDE INTERIOR
CROSS-SECTION

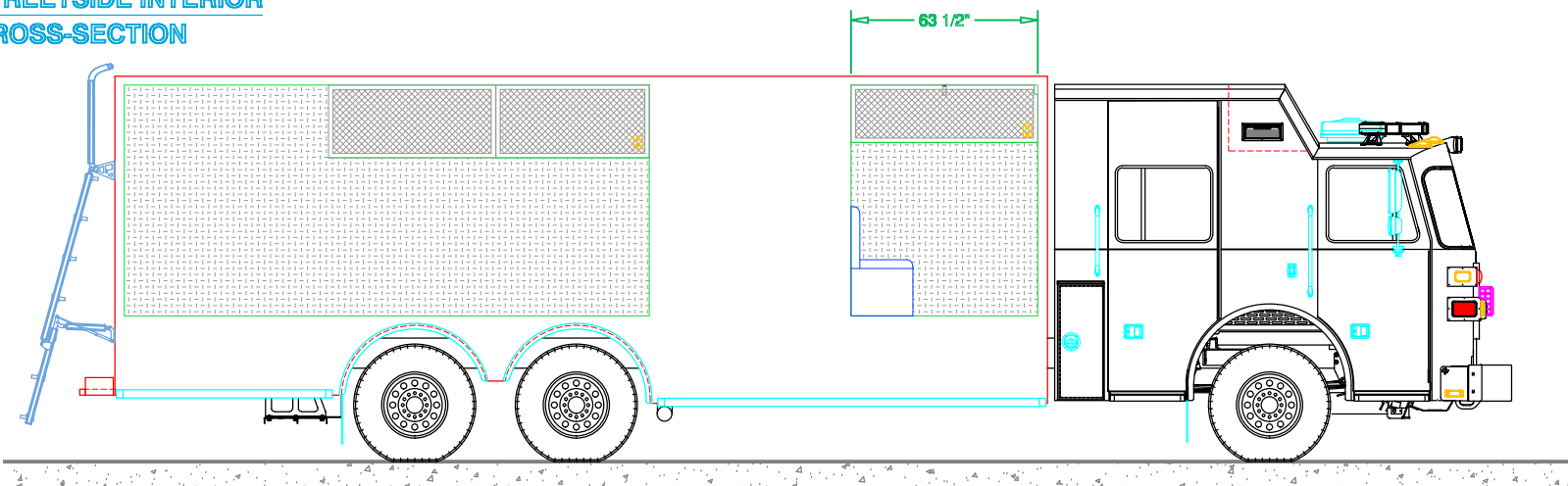

THIS PRINT IS PROVIDED ON A RESTRICTED BASIS AND IS NOT TO BE USED IN ANY WAY DETRIMENTAL TO THE INTEREST OF SUTPHEN CORPORATION.

SUTPHEN CORPORATION
FIRE APPARATUS SINCE 1890
7000 COLUMBUS-MARYSVILLE ROAD
AMLIN, OHIO 43002

**ELKHART
FIRE DEPARTMENT**

BODY SIZE: 28' BODY	UNIT TYPE: HEAVY RESCUE WALK - IN
BODY MATERIAL: 3/16" ALUMINUM	TRUCK NO: SVI #000
CHASSIS TYPE: SUTPHEN MONARCH 73" 20" RR	WHEELBASE: SEE DWG CAB TO AXLE: SEE DWG
FOUR DOOR	OVERALL LENGTH (OAL): SEE DWG OVERALL WIDTH (OAW): SEE DWG OVERALL HEIGHT (OAH): SEE DWG
DRAWN BY: BOG	DATE: April 8, 2022
DRAWING NO: Elkhart IN wt 28 PreCon2	SCALE: 3/16" = 1'-0"

SHEET **3** OF **3**