

LEFT SIDE COMPARTMENTATION			
COMPT	DOORS	DIMENSIONS	VOLUME
L1	ROLL-UP	40"W X 51 1/2"H X 26"D	28 CU. FT.
L2	ROLL-UP	59"W X 21 1/2"H X 14 1/2"D	11 CU. FT.
L3	ROLL-UP	51 1/2"W X 51 1/2"H X 26"D	40 CU. FT.
RIGHT SIDE COMPARTMENTATION			
COMPT	DOORS	DIMENSIONS	VOLUME
R1	ROLL-UP	40"W X 51 1/2"H X 26"D	28 CU. FT.
R2	ROLL-UP	59"W X 21 1/2"H X 14 1/2"D	11 CU. FT.
R3	ROLL-UP	51 1/2"W X 51 1/2"H X 26"D	40 CU. FT.
REAR STEP COMPARTMENT			
COMPT	DOORS	DIMENSIONS	VOLUME
A1	ROLL-UP	39 1/2"W X 39"H X 31"D	27 CU. FT.
REAR CREW SEAT COMPARTMENT			
COMPT	DOORS	DIMENSIONS	VOLUME
C1	HINGED	47"W X 15"H X 18 1/2"D	8 CU. FT.

14 1/2" DEEP, UPPER
FULL HEIGHT, FULL DEPTH

14 1/2" DEEP, UPPER
FULL HEIGHT, FULL DEPTH

TOTAL STORAGE: 193 CU. FT.

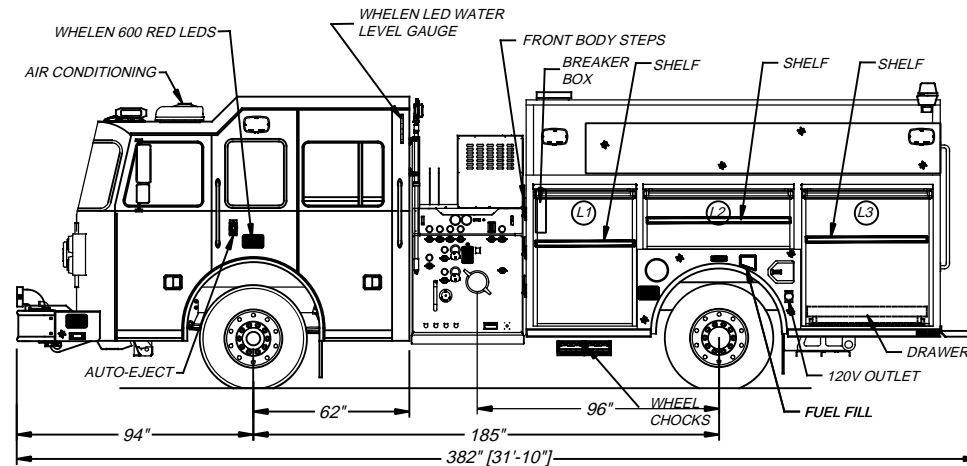
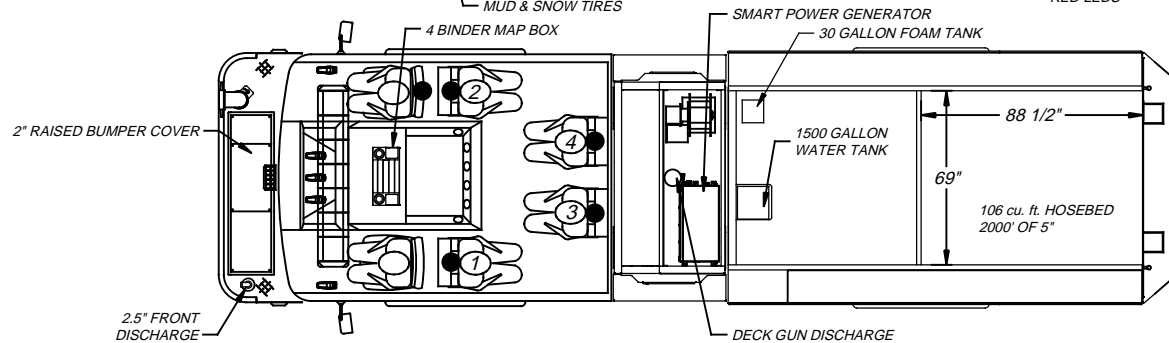
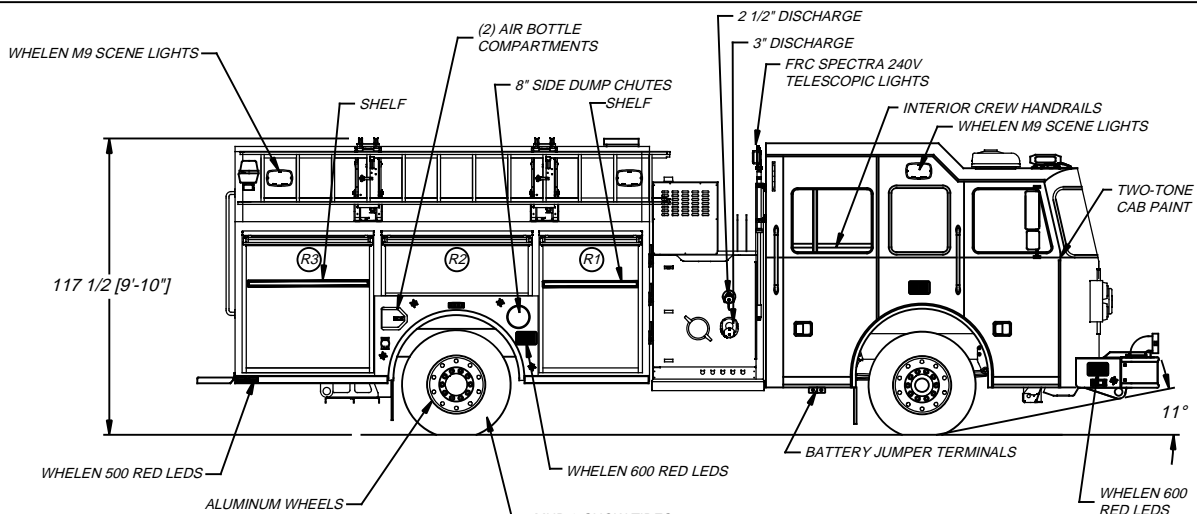
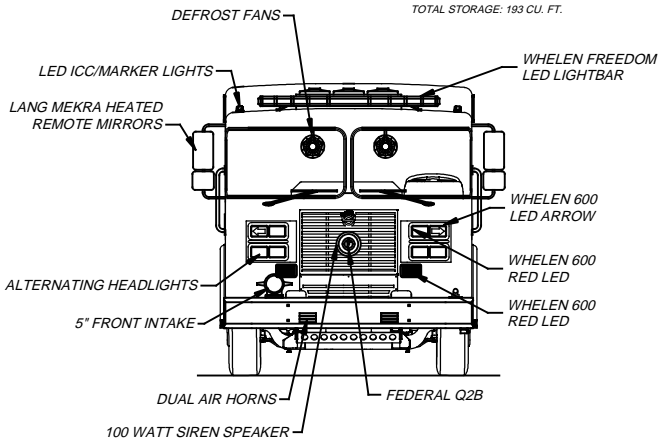

DIMENSIONS SHOWN ON THIS DRAWING ARE APPROXIMATE AND ARE SUBJECT TO MINOR DEVIATIONS DURING CONSTRUCTION.

IN THE EVENT OF A DISCREPANCY BETWEEN THE SUTPHEN SPECIFICATIONS AND DRAWING, THE SUTPHEN SPECIFICATIONS SHALL PREVAIL.

DRAWING IS FOR REFERENCE ONLY. SOME ITEMS PROPOSED MAY NOT BE SHOWN OR NOTED.

CUSTOMER APPROVAL

NAME:

TITLE:

DATE:

B

MISC CHANGES PER SHOP ORDER

JNH

2/11/2016

DRAWN BY:

J.HAULMAN

A

MISC CHANGES PER PRE-CONSTRUCTION MEETING

JNH

1/20/2016

DATE:

12/4/2015

REV.

DESCRIPTION

BY

DATE

DATE:

12/4/2015

DWG. NO.:

HS-5771

THIS PRINT IS PROVIDED ON A RESTRICTED BASIS AND IS NOT TO BE USED IN ANY WAY DETRIMENTAL TO THE INTEREST OF SUTPHEN CORPORATION.



SUTPHEN CORPORATION

FIRE APPARATUS - SINCE 1890

6450 EITERMAN ROAD DUBLIN, OH 43016

LAKE TWP. FIRE DEPARTMENT

MILLBURY, OH

PROGRAM 1 G7

HS-5771