

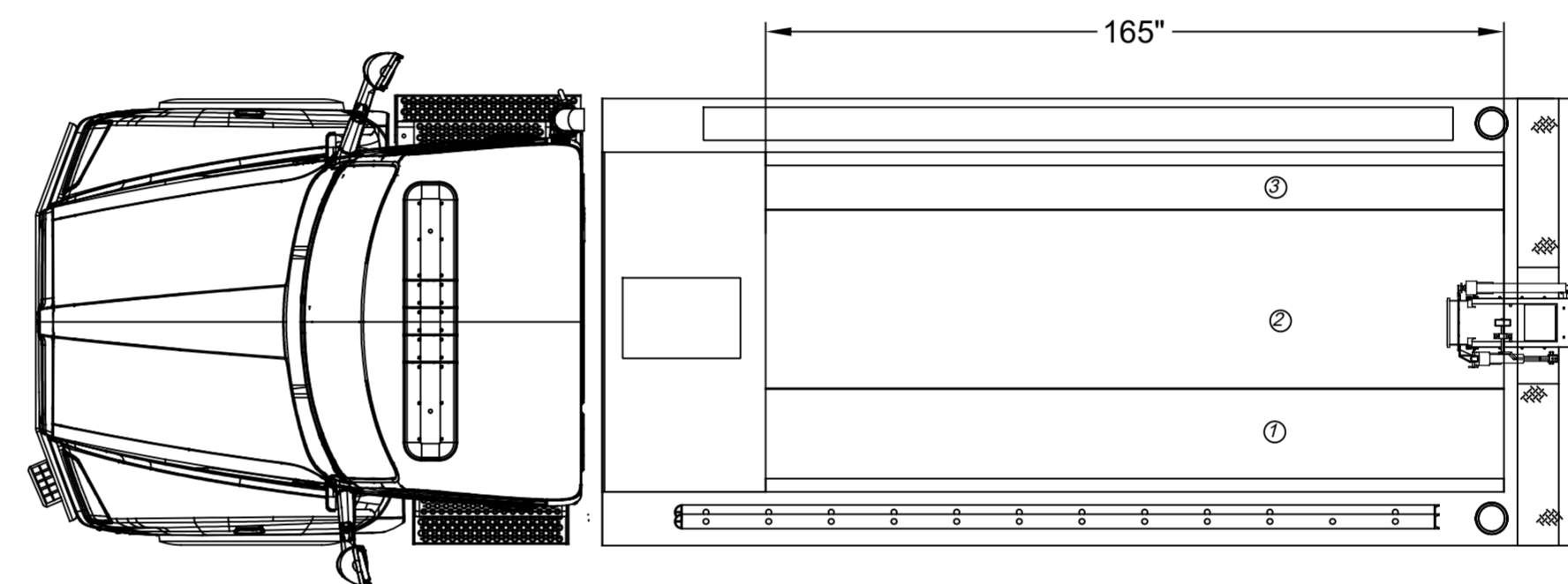

Left Side Compartmentation				
Compt	Doors	Opening Dimensions	Inside Dimensions	Volume
L1	Roll Up	23x30	WxHxD 30x40x24.25	16.8 CU FT
Right Side Compartmentation				
Compt	Doors	Opening Dimensions	Inside Dimensions	Volume
R1	Roll Up	53x30	60x40x24.25	33.7 CU FT
R2	Roll Up	23x30	30x40x24.25	16.8 CU FT
Total Volume				67.3 CU Ft

**HALE DSD 1000 GPM PTO  
3000 GALLONS OF WATER**

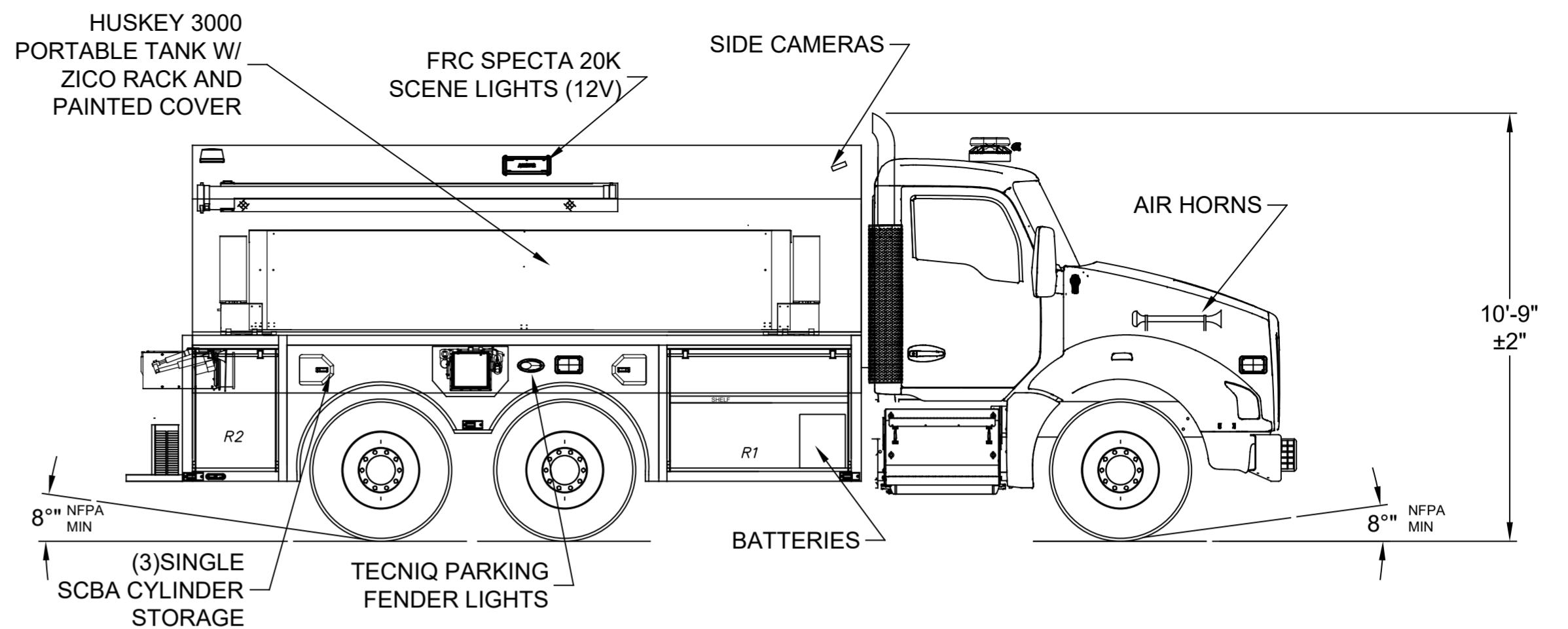
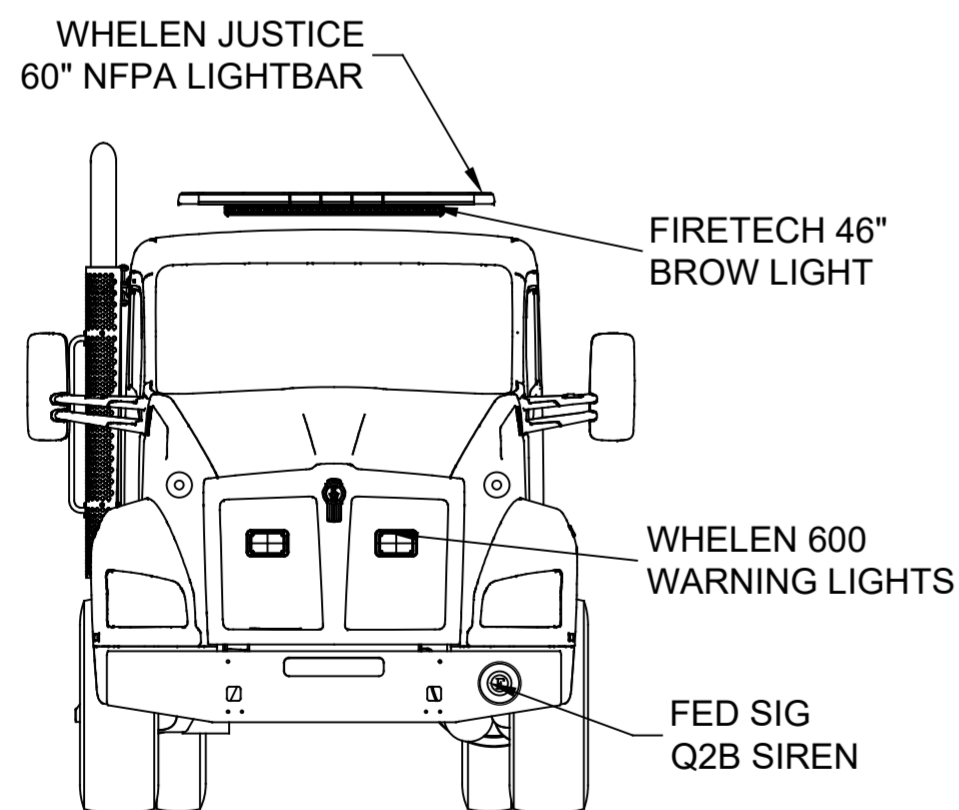
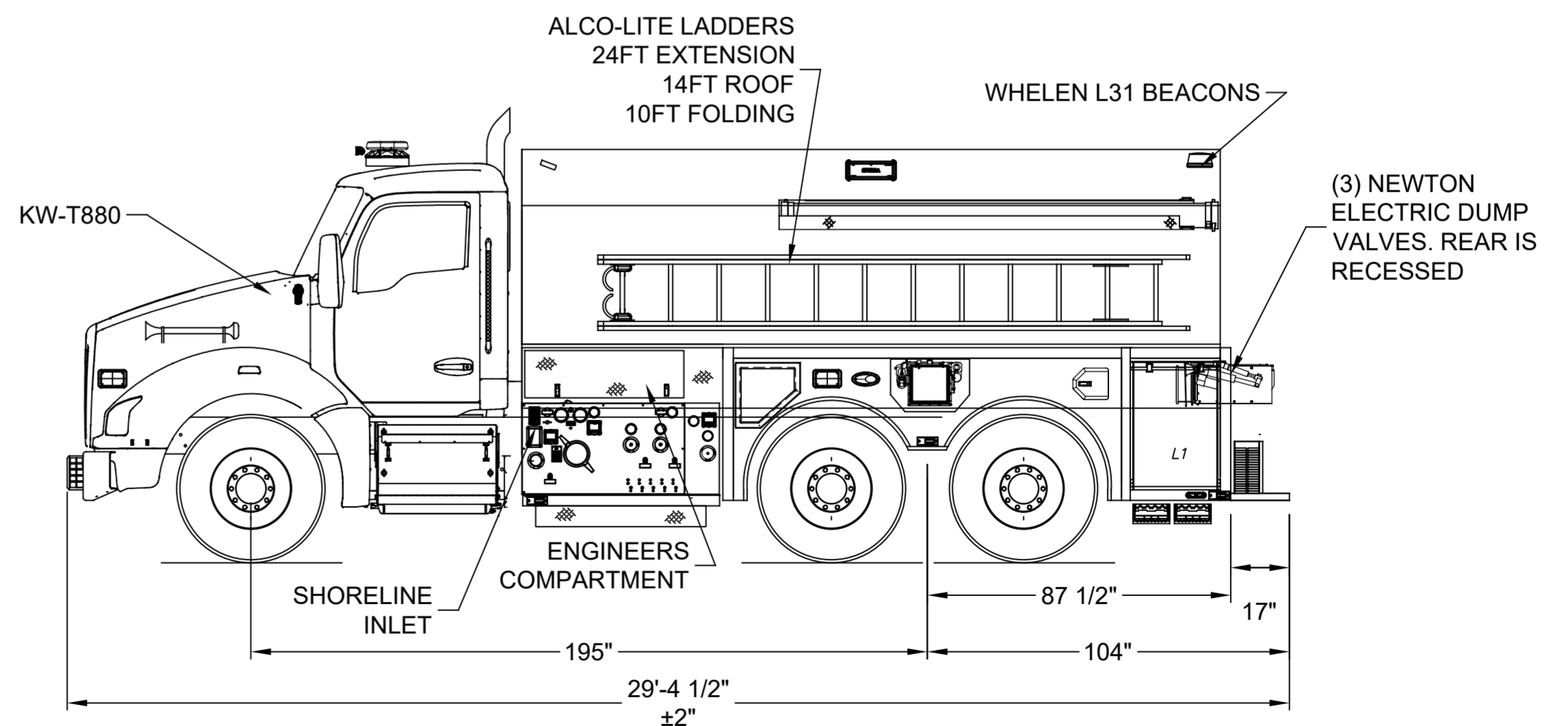

**Hose Load**  
1:500ft of 3"  
2:500ft of 5"  
3:200ft of 1-3/4"



DIMENSIONS SHOWN ON THIS DRAWING ARE APPROXIMATE AND ARE SUBJECT TO MINOR DEVIATIONS DURING CONSTRUCTION.	CUSTOMER APPROVAL		DRAWN BY: S.DORFMAN	DATE: 8/26/20	MFG. FACILITY: EAST	 <b>AVILLA FIRE DEPARTMENT AVILLA, IN</b>
	NAME: _____	TITLE: _____				
IN THE EVENT OF A DISCREPANCY BETWEEN THE SUTPHEN SPECIFICATIONS AND DRAWING, THE SUTPHEN SPECIFICATIONS SHALL PREVAIL.	DATE: _____	THIS PRINT IS PROVIDED ON A RESTRICTED BASIS AND IS NOT TO BE USED IN ANY WAY DETRIMENTAL TO THE INTEREST OF SUTPHEN CORPORATION.				