

LEFT SIDE COMPARTMENTATION				
COMPT	DOORS	OPENING DIMENSIONS	INSIDE DIMENSIONS	VOLUME
L1	ROLL-UP	25" w X 56 7/8" h	31 1/2" w X 66" h X 27 1/4" d	32 CU. FT.
L2	ROLL-UP	57" w X 27 5/8" h	61 1/2" w X 36 1/2" h X 27 1/4" d	35 CU. FT.
L3	ROLL-UP	50" w X 56 7/8" h	53 1/2" w X 66" h X 27 1/4" d	55 CU. FT.

RIGHT SIDE COMPARTMENTATION				
COMPT	DOORS	OPENING DIMENSIONS	INSIDE DIMENSIONS	VOLUME
R1	ROLL-UP	25" w X 50 7/8" h	31 1/2" w X 66" h X 27 1/4" d	24 CU. FT.
R2	ROLL-UP	57" w X 21 5/8" h	61 1/2" w X 36 1/2" h X 10 1/2" d	13 CU. FT.
R3	ROLL-UP	50" w X 50 7/8" h	53 1/2" w X 66" h X 27 1/4" d	42 CU. FT.

REAR STEP COMPARTMENTS				
COMPT	DOORS	OPENING DIMENSIONS	INSIDE DIMENSIONS	VOLUME
A1	ROLL-UP	37 1/2" w X 31" h	40" h X 40" w X 30 1/2" d	27 CU. FT.

TOTAL STORAGE: 228 cu. ft.

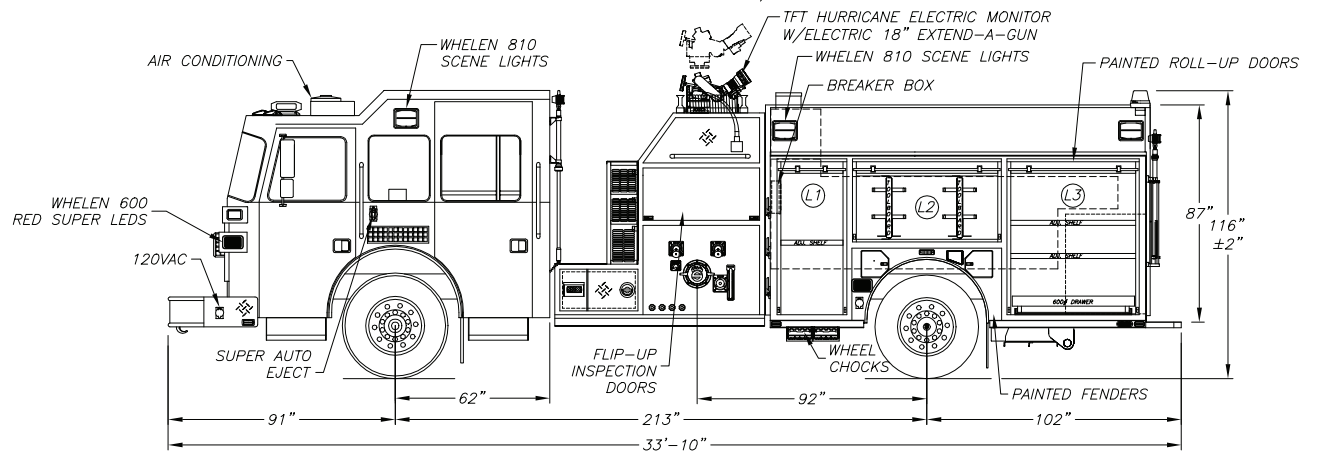
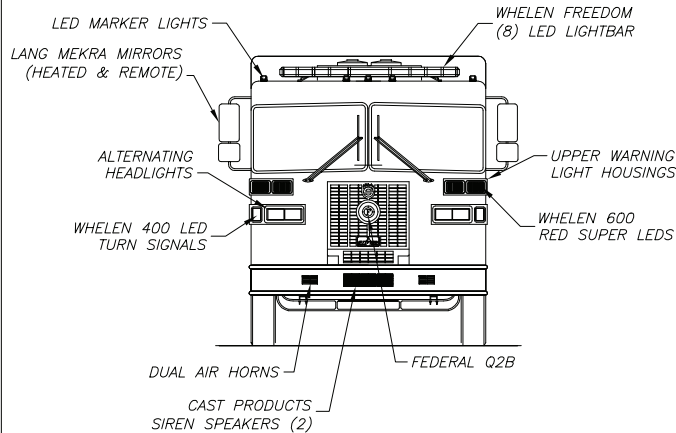
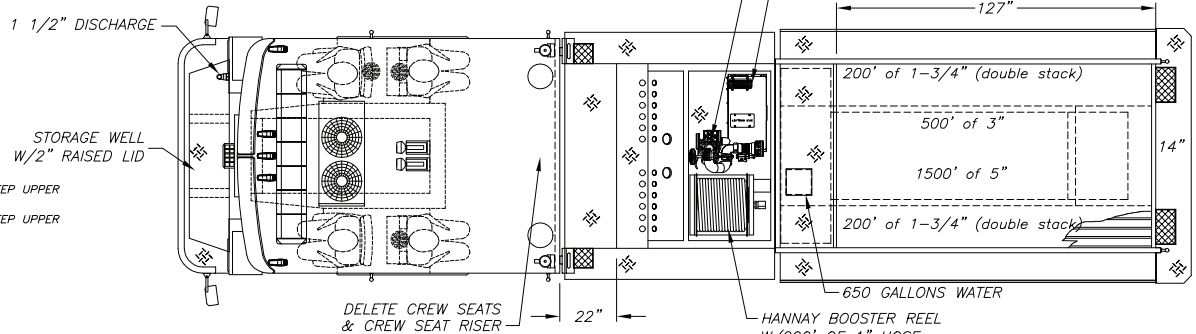

NOTE:
1) DECKGUN FLANGE FLUSH WITH SIDE METAL.

THE INFORMATION PRESENTED ON THIS DOCUMENT IS TO BE USED FOR ILLUSTRATIVE PURPOSES ONLY AND IT MAY NOT REFLECT, AESTHETICALLY OR OTHERWISE, PAST OR PRESENT MANUFACTURED PRODUCTS. SUTPHEN CORPORATION RESERVES THE RIGHT TO MAKE CHANGES IN THE DESIGN OF OUR PRODUCTS AT ANY TIME, WITHOUT NOTIFICATION.

The undersigned approves this data for construction in accordance with any changes as indicated on these drawings.

APPROVED BY: _____ DATE: _____
(Authorized Fire Dept. Representative)

SALES REPRESENTATIVE: _____ DATE: _____

REV.	DESCRIPTION	BY	DATE
C	UPDATED REV TO MATCH SHOP ORDER	CAG	7/24/09
B	UPDATED REV TO MATCH SHOP ORDER	CAG	7/13/09
A	CHANGES FROM PRECONSTRUCTION MEETING	CAG	4/30/09

THIS PRINT IS PROVIDED ON A RESTRICTED BASIS AND IS NOT TO BE USED IN ANY WAY DETRIMENTAL TO THE INTERESTS OF SUTPHEN CORPORATION.

SUTPHEN CORPORATION
FIRE APPARATUS SINCE 1890
7000 COLUMBUS-MARYSVILLE ROAD
AMLIN, OHIO 43002

DR: C. GREEN
DATE: 2/26/09
SCALE: NONE
TOL: _____

WABASH FIRE DEPT.
WABASH, IN
AMBASSADOR CHASSIS
PA-02 30/53

NO. REQ'D:
DWG. NO.: HS-4671